

User's Manual

Electrostatic Sprayer

Model:

16L-VEB-5in1

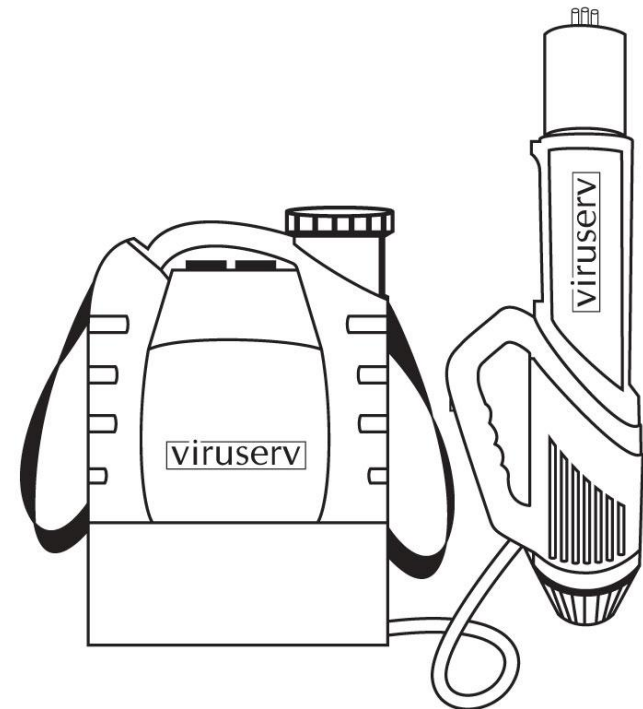

Notice to Users:

The User's Manual is a part of the electrostatic sprayer. Please keep it in good condition. To use and maintain the product in good working condition, please read the User's Manual carefully before operation. If you have any doubt, contact the supplier.

The electrostatic sprayer shall be operated, maintained, and repaired by persons familiar with its performance, and know how to operate it safely. The manufacturer shall not be liable for decreased reliability, machine damage, or personal injury arising from unauthorized modifications to the electrostatic sprayer.

PACK LIST:

- Reservoir backpack with 2-filters and lid
- Shoulder straps
- Lithium battery charger
- Wand
- Blower
- Tri-tip nozzle for blower
- Cone nozzle for wand
- Double-tipped nozzle for wand
- Blue nozzle for wand
- Additional O washers
- User manual

ASSEMBLY:

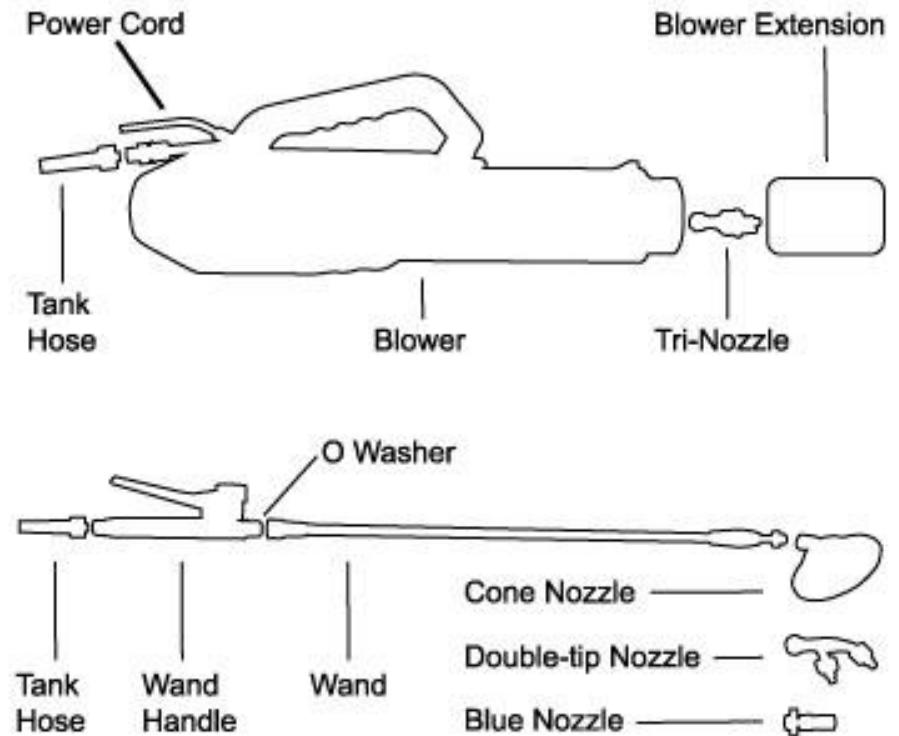

1. Lid
2. Shoulder Straps
3. Reservoir
4. Charging Port
5. Power on/off
6. Battery
7. Diaphragm Pump
8. High-voltage Generator
9. Bottom Cover
10. Hose
11. Wand Handle
12. Wand
13. Nozzle
14. Blower tri-nozzle
15. Blower
16. Blower on/off
17. Hose Connector
18. Blower power cord

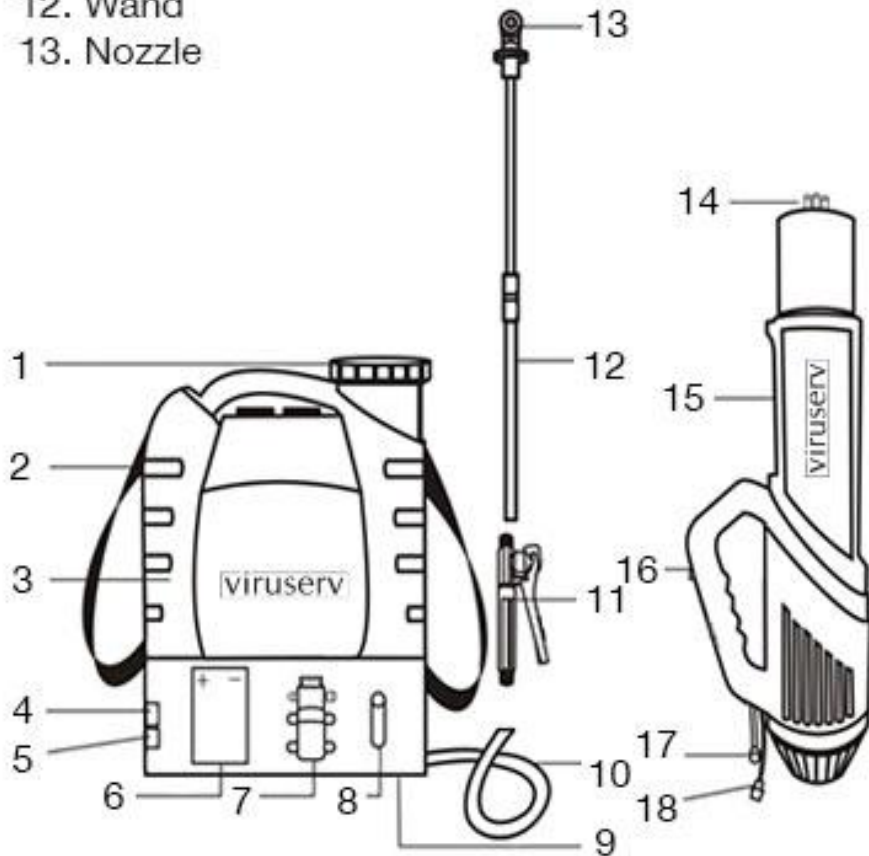

3.

OPERATION:

1. Plug lithium battery charger into charging port and charge until red light turns green.
2. Attach either Blower or Wand to the Hose.
3. Pour disinfectant into Reservoir and secure Lid.
4. Place backpack on back using Shoulder Straps.
5. Turn on Power with left hand.
6. Disinfect desired surfaces.
7. When finished, pour any remaining disinfectant out of reservoir.
8. Pour in some water to rinse through Blower/Wand for a minimum of 15-seconds to clean out any disinfectant.
9. Pour out any unused rinse water.
10. Return to storage location and plug lithium battery charger into charging port.

SPRAYING METHOD:

- Do not walk into the chemicals as you are spraying. The height of the nozzle depends on how much you want to apply.
- Typically, keeping the Blower with fan off 3-feet away from the objects provides adequate coverage, but your application may require adjustments.
- When using the Blower with the fan on, the range is approximately 4~6 feet. With the fan on, the range is up to 18 feet.

4.

WARNING:

If the liquid spills from the mouth of the reservoir and soaks the reservoir's exterior, and the operator's clothing and body, it is susceptible to electrostatic leaks that irritate the skin. Therefore, it is essential to tighten the lid of the reservoir after filling and prevent spillage from the mouth of the reservoir during operation. Keeping the exterior of the reservoir dry and clean is vital to ensure the electrostatic absorption and comfortable handling of the sprayer.

I) Safety and Operational Considerations

- Attention must be paid to the filtration of liquid and water to avoid clogging the nozzle and affecting operation. If the nozzle is blocked, the particles must be removed before starting the machine operation.
- Operators must be aware of the properties and protective methods used to avoid direct physical contact with chemicals. Spraying with chemicals that have a corrosive effect on plastics and metals should be avoided. Do not spray with wettable powder to prevent clogging the nozzle.
- After the electrostatic sprayer has been used, the interior of the drum and the injection system shall be cleaned and wiped down with water promptly before being placed in an appropriate storage location. Cleaning method: fill the reservoir with water and spray the machine for 15-seconds, pour out the remaining water and wipe clean.

- Do not submerge the pump or battery in water. Do not use the electrostatic sprayer in a flammable or explosive environment.
- Care should be taken to keep the exterior of the reservoir and the wand in a clean and dry condition during operation and prohibit physical contact with passers-by during the process. Do not touch the spray rod or the charging socket with your hand during operation.
- **After operating, the handle switch should be turned off, then turn off the electrostatic/pump switch on the reservoir.**
- After charging, leave it for 10-minutes before using. The battery should be charged for maintenance at least once-a-month. Proper use and maintenance of the battery can significantly extend the life of the battery.
- The machine is equipped with tens of thousands of high-voltage electricity and disassembly of the machine is strictly prohibited.
- The use of special working fluids, such as strong acids and bases, is not permitted.
- Chemicals should be used following the safety instructions provided by the manufacturer.

Working Principles

- The sprayer uses a 12V lithium battery as the power source to drive the water pump and high-voltage electrostatic generator at the same time. When the high-speed pump squeezes out the electrostatic charge from the tiny nozzle, the tiny droplets are sprayed under the combined action of gravity, external force, and electrostatic force directly to the target.

Scope of Applications

- This machine can be used for sanitary epidemic prevention and disinfection of factories, warehouses, schools, airports, hospitals, retail locations, and more.

Specifications

- Empty weight: 9.0 lbs
- Size: 14.5 x 7.5 x 21.5
- Reservoir Capacity: 16-liters (4.2 gallons)
- Battery capacity: 12V, 10aH Lithium
- Charger Input: AC 110
- Continuous working time: 4~6 hours
- Electrostatic voltage output: 1.5 - 3 kV
- Pressure: 0.15 - 0.4 mpa
- Median droplet diameter: 80 microns (40~120)
- Flow Rate (blower w/o fan): 1-gallon per hour
- Spray distance (blower w/o fan): 3~6 feet
- Spray distance (blower w/ fan): \leq 18 feet
- Flow Rate (cone nozzle): 1.5-gallons per hour
- Spray distance (cone nozzle): 3~6 feet

After-Sales Service

- This machine has been strictly inspected and passed factory quality-control. If the new device is unable to operate as designed, please contact your supplier.

Warranty Coverage

- One-year warranty for the whole machine and one-year for major parts, except for normal wear-and-tear. The main components include the battery, charger, high-voltage generator, and water pump. One-month warranty on all wear parts. Wear parts include seals, nozzles, lids, etc.
- The battery IS NOT covered under warranty if it is over-discharged, or improper charging maintenance causes a shortened battery life. Additionally, the battery IS NOT covered under warranty if there is an electrical surge while charging the battery.
- The pump IS NOT covered under warranty due to external forces, corrosive liquid immersion, or chemical impurities.
- If repairs are required, please contact your supplier.
- In the event of human-caused damage during the warranty period, warranty personnel may charge for the cost of repair.